

REVISIONS		
REV.	DESCRIPTION	DATE
A	RELEASED: DMG	9-15-98
B	CORRECT WALL THICKNESS DIMENSIONS	11-23-98
C	CLARIFY NOTCH DIMS. & ANGLE TOLERANCE	3-15-99
D	CHGE STD. RADII FROM 0.010 MAX. TO 0.010±0.005	4-9-99
E	CHGE STD. RADII FROM 0.010±0.005 TO 0.015 MAX.	5-11-99
F	MATCH NOTCH DIM. OF VENDOR AND CUSTOMER	08-25-99

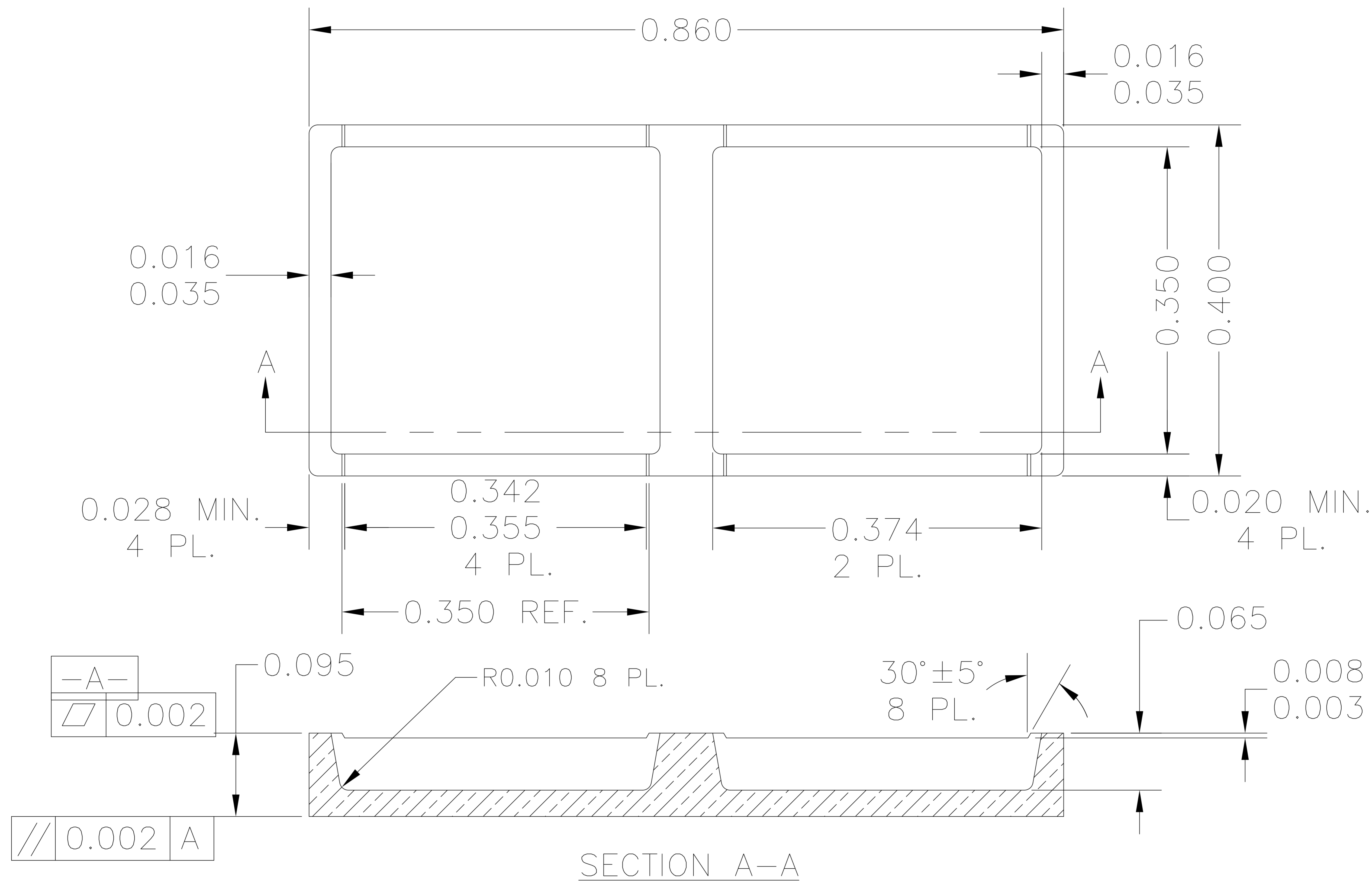

SECTION A-A

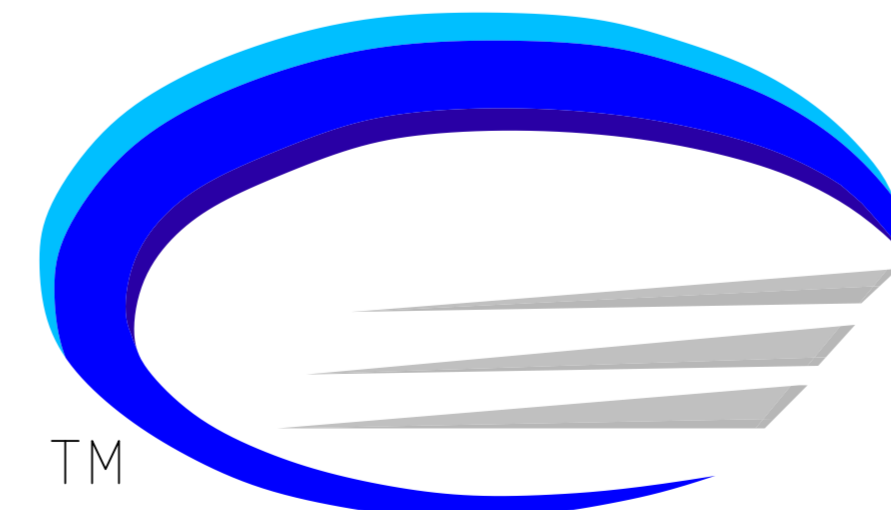

THIS DRAWING CONTAINS INFORMATION THAT IS CONFIDENTIAL AND PROPRIETARY PROPERTY OF R.J.R. POLYMERS, INC., AND ITS DESIGN, DETAIL AND INVENTION, ARE THE PROPERTY OF R.J.R. POLYMERS, INC., SUBMITTED TO THE RECIPIENT IN CONFIDENCE AND SHALL NOT BE COPIED IN ANY MANNER NOR DISCLOSED TO ANY OUTSIDE PARTY WITHOUT THE EXPRESS WRITTEN CONSENT OF AN AUTHORIZED OFFICER OF THIS COMPANY. THEY SHALL BE USED EXCLUSIVELY FOR REFERENCE WORK ON CONTRACTS OR PROPOSALS SUBMITTED BY R.J.R. POLYMERS, INC. AND SHALL BE RETURNED ON REQUEST. THIS DRAWING MUST BE KEPT ONLY IN THE CONFIDENTIAL FILES OF R.J.R. POLYMERS, INC., WHEN NOT IN USE. ALL RIGHTS RESERVED.

RJR POLYMERS, INC

7875 EDGEWATER DR., OAKLAND, CA. 94621

TOLERANCES ARE IN INCHES:  
(UNLESS OTHERWISE SPECIFIED)  
FRACTIONS: N/A  
DECIMALS: ±1% NLT±0.005

±1°  
⊥ ±1/32"/FT.  
∥ 0.003"/IN.  
DRAFT < 10' MAX.  
RADII: 0.015 MAX.

CADFILE:  
Q:\Drawings\...\2012  
CLIENT #

0.860 X 0.400 X 0.095

CERAMIC LID  
DUAL MAC PAC

A	1	WHITE Al <sub>2</sub> O <sub>3</sub>	0.860x0.0400x0.095
ITEM	QTY	MATERIAL	

DATE	SCALE	DRAWN BY	DWG SIZE	CHECKED BY	PART/DWG #	REV	1
7/13/98	NTS	NRC	A		2012	F	1