

REVISIONS		
REV.	DESCRIPTION	DATE
A	RELEASED: GEIDEL	10-16-98
B	CHANGE LID HEIGHT DIM. FROM 0.077 TO 0.072	12-4-98
C	TOLERANCES CHANGED PER ECR 2295-030609	6-9-03
D	ERROR ON CAVITY DEPTH DIMENSION CORRECTED	6-18-03

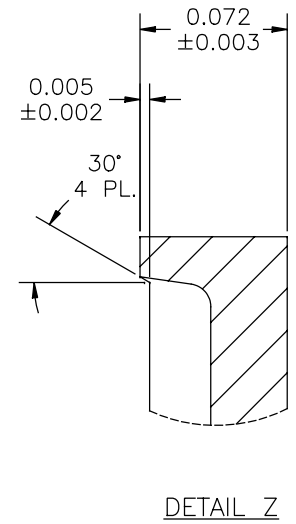
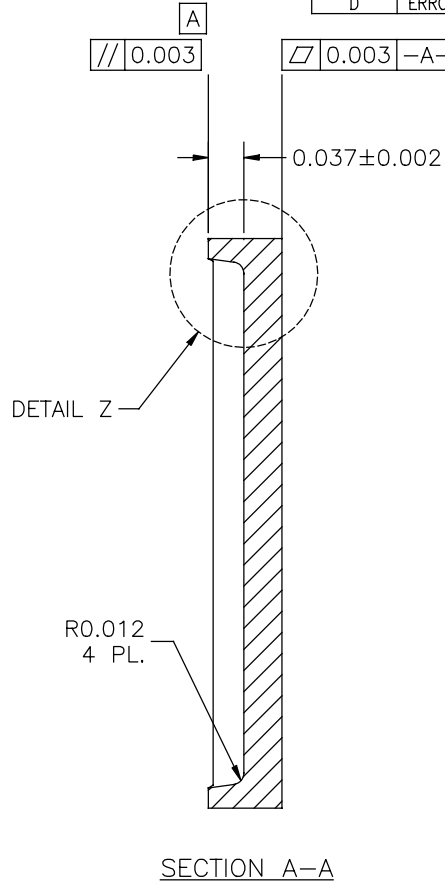
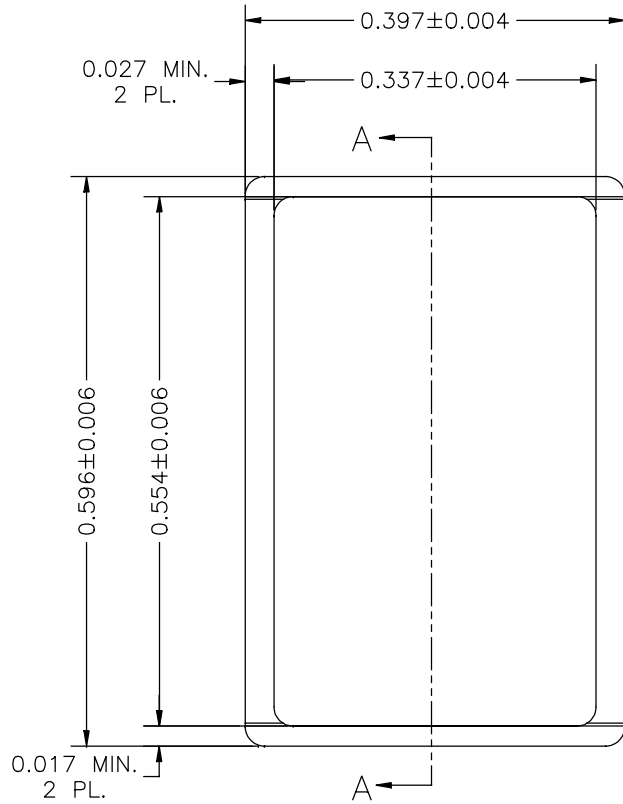

<table border="1" style="width:100%; border-collapse: collapse;"> <tr> <td style="width: 50%;">APPROVAL SIGNATURES</td> <td style="width: 50%;">DATE</td> </tr> <tr> <td>Configuration Control</td> <td></td> </tr> <tr> <td>Purchasing</td> <td></td> </tr> <tr> <td>Quality Assurance</td> <td></td> </tr> </table>	APPROVAL SIGNATURES	DATE	Configuration Control		Purchasing		Quality Assurance		<p style="text-align: center;"><b>RJR POLYMERS, INC</b></p> <p style="text-align: center;">7875 EDGEWATER DR., OAKLAND, CA. 94621</p> <p style="font-size: small;">THIS DRAWING CONTAINS INFORMATION THAT IS CONFIDENTIAL AND PROPRIETARY PROPERTY OF R.J.R. POLYMERS, INC., AND ITS DESIGN, DETAIL AND INVENTION, ARE THE PROPERTY OF R.J.R. POLYMERS, INC., SUBMITTED TO THE RECIPIENT IN CONFIDENCE AND SHALL NOT BE COPIED IN ANY MANNER NOR DISCLOSED TO ANY OUTSIDE PARTY WITHOUT THE EXPRESS WRITTEN CONSENT OF AN AUTHORIZED OFFICER OF THIS COMPANY. THEY SHALL BE USED EXCLUSIVELY FOR REFERENCE WORK ON CONTRACTS OR PROPOSALS SUBMITTED BY R.J.R. POLYMERS, INC. AND SHALL BE RETURNED ON REQUEST. THIS DRAWING MUST BE KEPT ONLY IN THE CONFIDENTIAL FILES OF R.J.R. POLYMERS, INC., WHEN NOT IN USE. ALL RIGHTS RESERVED.</p>	<p style="text-align: center;">0.596 x 0.397 x 0.072 CERAMIC LID</p> <table border="1" style="width:100%; border-collapse: collapse;"> <tr> <td>DATE</td> <td>SCALE</td> <td>DRAWN BY</td> <td>DWG SIZE</td> <td>CHECKED BY</td> <td>PART/DWG #</td> <td>REV</td> </tr> <tr> <td>10/16/98</td> <td>NTS</td> <td>DMG</td> <td>A</td> <td></td> <td>2295</td> <td>D</td> </tr> </table>	DATE	SCALE	DRAWN BY	DWG SIZE	CHECKED BY	PART/DWG #	REV	10/16/98	NTS	DMG	A		2295	D
APPROVAL SIGNATURES	DATE																							
Configuration Control																								
Purchasing																								
Quality Assurance																								
DATE	SCALE	DRAWN BY	DWG SIZE	CHECKED BY	PART/DWG #	REV																		
10/16/98	NTS	DMG	A		2295	D																		
<p style="font-size: small;">TOLERANCES ARE IN INCHES: (UNLESS OTHERWISE SPECIFIED) FRACTIONS: ±1/16" DECIMALS: X.XX = ±0.01           X.XXX = ±0.005</p> <p style="font-size: small;">∠ ±1" ±1/32"/FT. □ 0.003"/IN. DRAFT ≤ 8" MAX. RADI: 0.020 TYP.</p>		<table border="1" style="width:100%; border-collapse: collapse;"> <tr> <td>CADFILE:</td> <td rowspan="2" style="text-align: center;">0.596 x 0.397 x 0.072 CERAMIC LID</td> </tr> <tr> <td>Q: \DRAWINGS\...\2295D.DWG</td> </tr> <tr> <td>CLIENT #</td> <td></td> </tr> </table>	CADFILE:	0.596 x 0.397 x 0.072 CERAMIC LID	Q: \DRAWINGS\...\2295D.DWG	CLIENT #																		
CADFILE:	0.596 x 0.397 x 0.072 CERAMIC LID																							
Q: \DRAWINGS\...\2295D.DWG																								
CLIENT #																								
<table border="1" style="width:100%; border-collapse: collapse;"> <tr> <td>QTY</td> <td>ITEM</td> <td>MATERIAL</td> </tr> <tr> <td style="text-align: center;">8</td> <td style="text-align: center;">-</td> <td style="text-align: center;">WHITE ALUMINA (96% MIN.)</td> </tr> </table>		QTY	ITEM	MATERIAL	8	-	WHITE ALUMINA (96% MIN.)																	
QTY	ITEM	MATERIAL																						
8	-	WHITE ALUMINA (96% MIN.)																						