

REVISIONS			DATE
REV	BY	DESCRIPTION	
A	BLTYH	RELEASED TO ACTIVE PER R&D	5-16-00

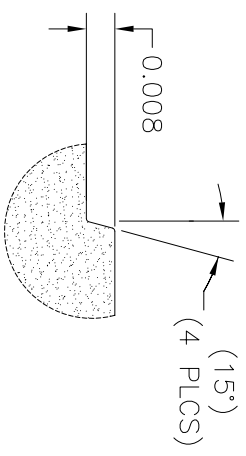

DETAIL N
NOTCH CRITERIA

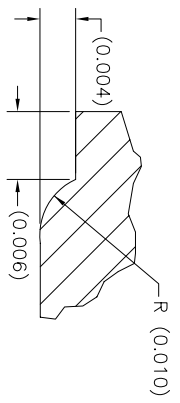

DETAIL E
OPTIONAL EDGE

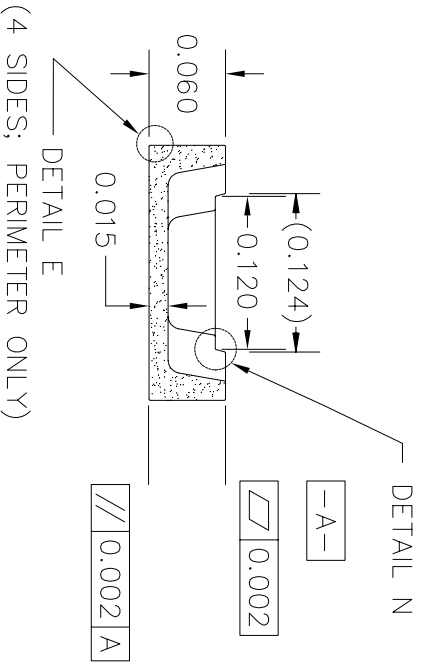
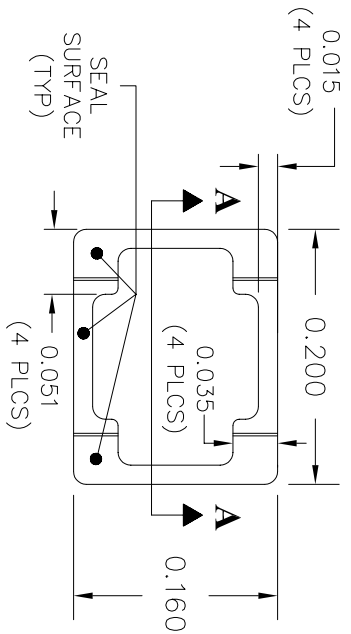

SECTION A-A

Approval Signatures	DATE
Configuration Control	
Customer Service	
Manufacturing	
Purchasing	
Quality Assurance	

BILL OF MATERIALS

PART #	DESCRIPTION
1790	EPOXY APPLIED ONTO SEAL SURFACE: 0.005 TO 0.012 THICK (EPOXY NOT DEPICTED IN ILLUSTRATION ABOVE)
4262	WHITE CERAMIC LID WITHOUT EPOXY (SHOWN)

TOLERANCES ARE IN INCHES:
(UNLESS OTHERWISE SPECIFIED)
FRACTIONS: X XX = ±0.01
DECIMALS: XXXX = ±0.004
±1' ±1/32"/FT.
DRAFT < 10' MAX.
RADI: 0.010 MAX



THIS DRAWING CONTAINS INFORMATION THAT IS CONFIDENTIAL AND PROPRIETARY PROPERTY OF RJR POLYMERS, INC., AND ITS DESIGN, DETAIL AND INVENTION, ARE THE PROPERTY OF RJR POLYMERS, INC. AND ARE NOT TO BE REPRODUCED OR TRANSMITTED IN ANY MANNER NOR DISCLOSED TO ANY OUTSIDE PARTY WITHOUT THE EXPRESS WRITTEN CONSENT OF AN AUTHORIZED OFFICER OF THIS COMPANY. THEY SHALL BE USED EXCLUSIVELY FOR REFERENCE WORK ON CONTRACTS OR PROPOSALS SUBMITTED BY RJR POLYMERS, INC. AND SHALL BE RETURNED ON REQUEST. THIS DRAWING MUST BE KEPT ONLY IN THE CONFIDENTIAL FILES OF RJR POLYMERS, INC., WHEN NOT IN USE. ALL RIGHTS RESERVED.

RJR POLYMERS, INC.
7875 EDGEWATER DR., OAKLAND, CA. 94621

CAD FILE: Q:\DRAWINGS\...4262A.DWG	DATE 5-16-00	SCALE NIS	DRAWN BY DWB	DWG SIZE A	ASSEMBLY PART NUMBER FA4263	DRAWING # 4262	REV A
T1218							
WHITE CERAMIC NOTCHED LID ASSEMBLY							