

DRAWN	REV.	DESCRIPTION	DATE	APPROVED
D. LAM	01	INITIAL RELEASE.	01-22-07	

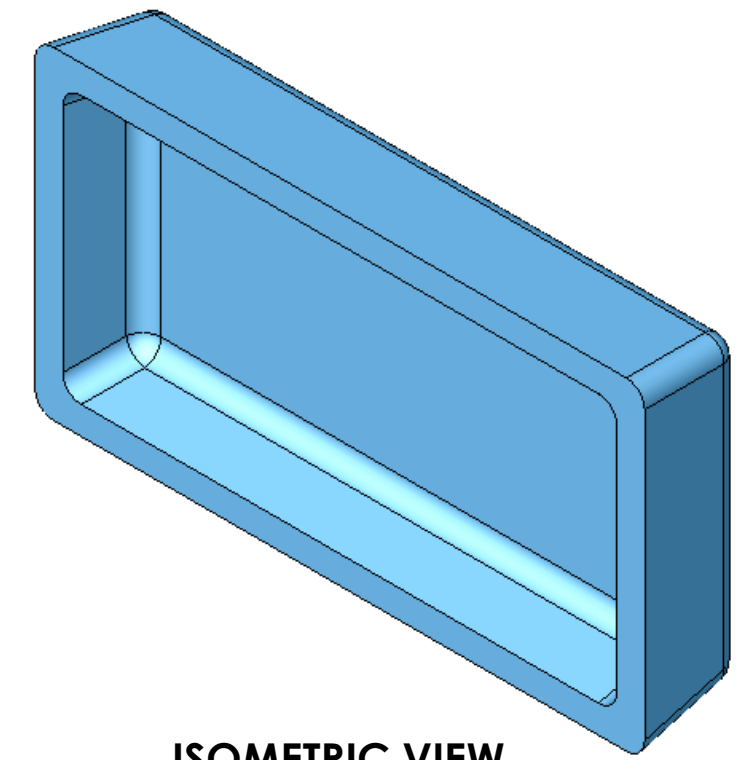

**SECTION B-B**

**ISOMETRIC VIEW**

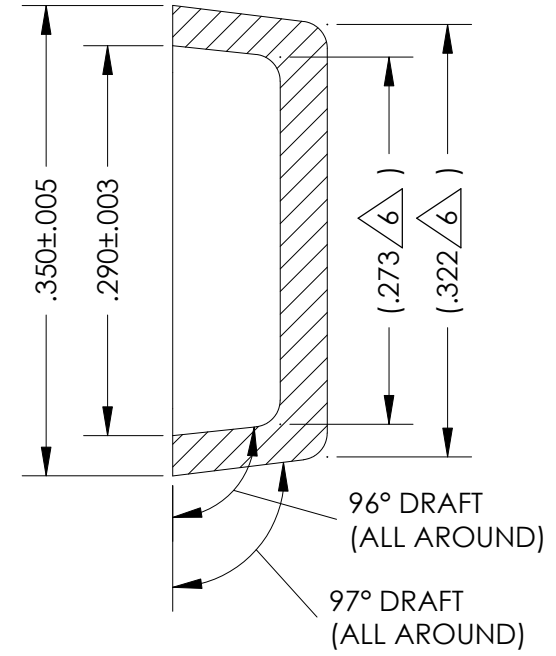
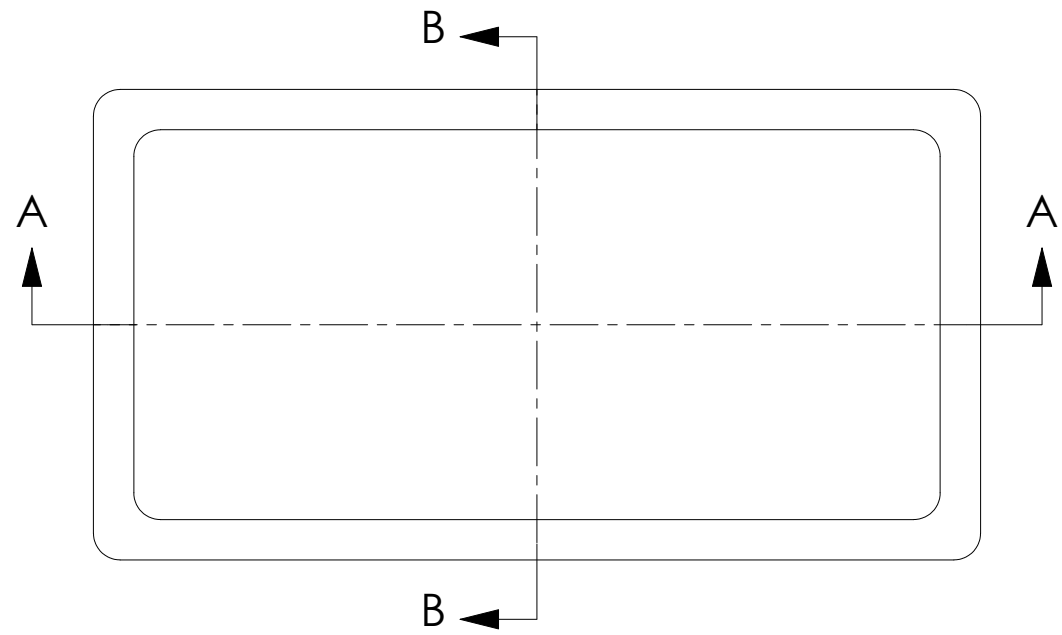
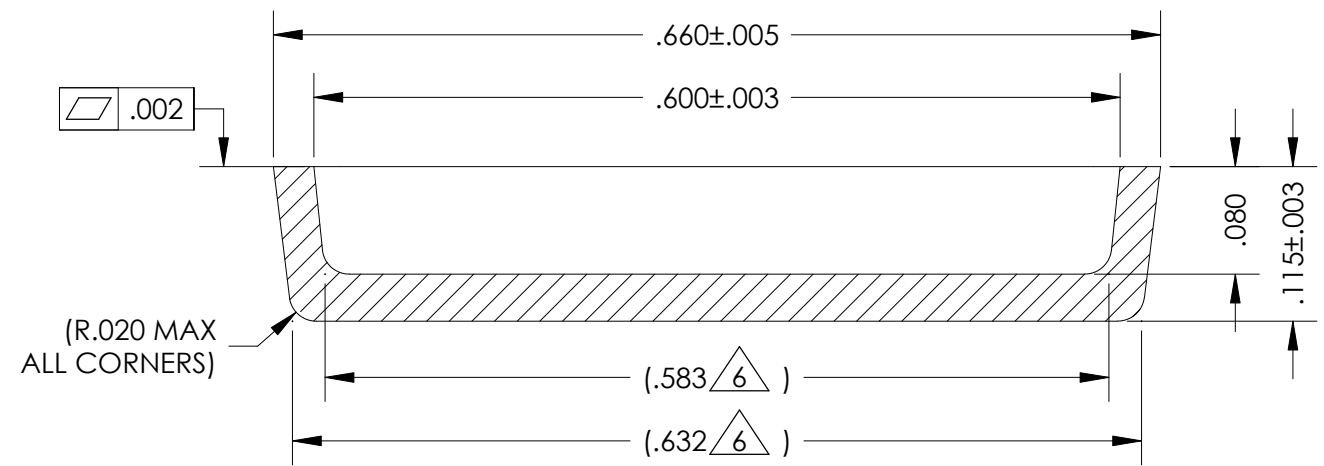

**SECTION A-A**

NOTES: UNLESS OTHERWISE SPECIFIED,

1. APPLICABLE STANDARDS/SPECIFICATIONS:  
ASME Y14.5M-1994, DIMENSIONING AND TOLERANCING  
ASME Y14.38-1999, ABBREVIATIONS AND ACRONYMS.
2. ALL EDGES AND CORNERS, R.020 MAX.
3. PARTS TO BE CLEAN AND FREE OF FOREIGN MATERIAL.
4. FLASH AND GATE REMNANTS NOT TO EXCEED .003".
5. LID MATERIAL: P/N 6111, BLK LCP.
6.  $\triangle$  DIMENSIONED TO VIRTUAL SHARP.

UNLESS OTHERWISE SPECIFIED: ALL DIMS IN INCHES & INCLUDE CHEM. APPLIED/PLATED FINISH. REMOVE BURRS & SHARP EDGES. DO NOT SCALE.		 THIS DRAWING CONTAINS INFORMATION THAT IS CONFIDENTIAL AND PROPRIETARY PROPERTY OF R.J.R. POLYMERS, INC., AND ITS DESIGN, DETAIL AND INVENTION, ARE THE PROPERTY OF R.J.R. POLYMERS, INC., SUBMITTED TO THE RECIPIENT IN CONFIDENCE AND SHALL NOT BE COPIED IN ANY MANNER NOR DISCLOSED TO ANY OUTSIDE PARTY WITHOUT THE EXPRESS WRITTEN CONSENT OF AN AUTHORIZED OFFICER OF THIS COMPANY. THEY SHALL BE USED EXCLUSIVELY FOR REFERENCE WORK ON CONTRACTS OR PROPOSALS SUBMITTED BY R.J.R. POLYMERS, INC. AND SHALL BE RETURNED ON REQUEST. THIS DRAWING MUST BE KEPT ONLY IN THE CONFIDENTIAL FILES OF R.J.R. POLYMERS, INC., WHEN NOT IN USE. ALL RIGHTS RESERVED.	
TOLERANCES: .XX = ±.005 .XXX = ±.002 ANGLES = ±1°			
MATERIAL: SEE NOTES		CAD FILE: 6154	
FINISH: -		CLIENT: -	
DATE: 1-22-07		SCALE: NTS	SIZE: B
DRAWN: D. LAM		CHK'D: -	P/N: 6154
		DATE: 1-22-07	REV: 01

**CONFIDENTIAL**

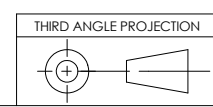

**LID, SMT COMB GENERATOR,  
.115 X .350 X .660**