

DRAWN	REV.	DESCRIPTION	DATE	APPROVED
D. LAM	01	INITIAL RELEASE	04-03-09	

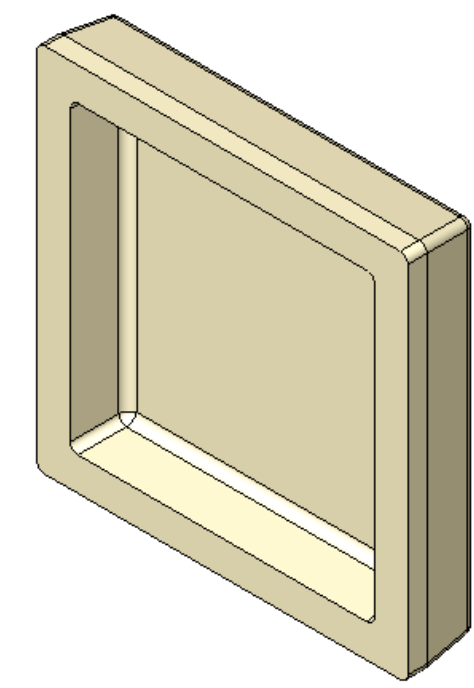

ISOMETRIC VIEW

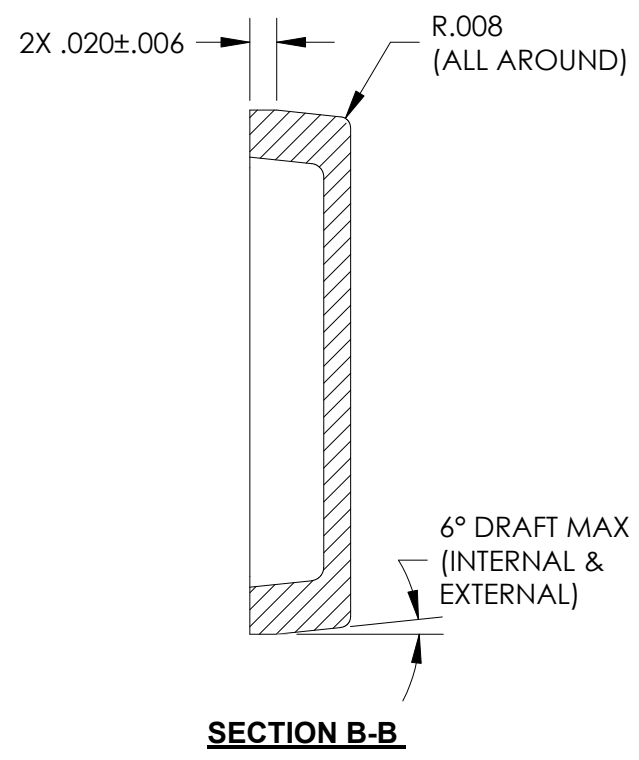
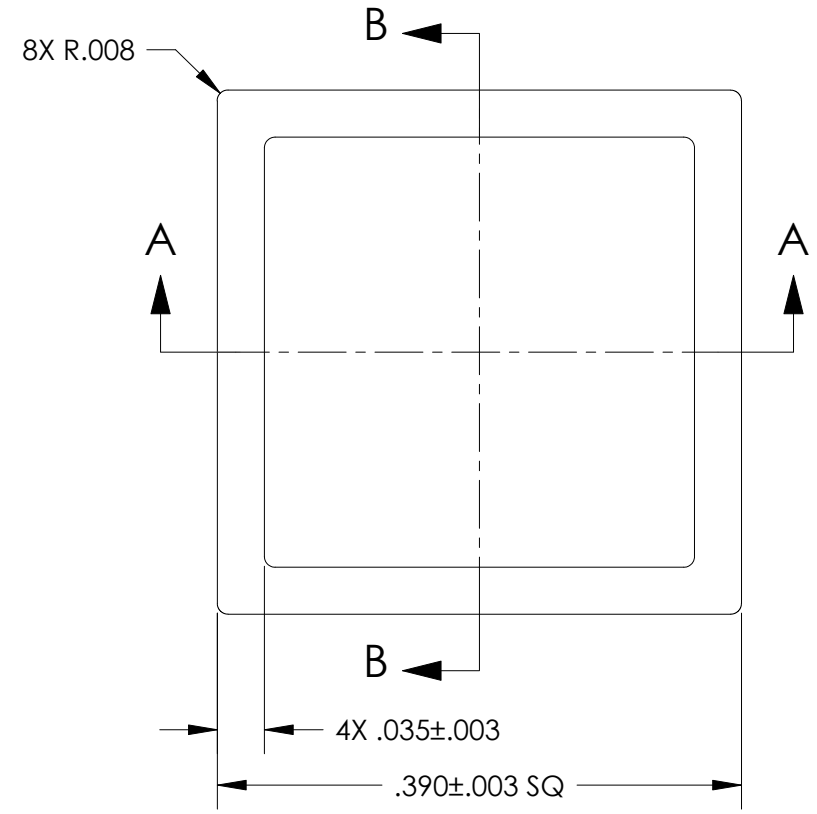
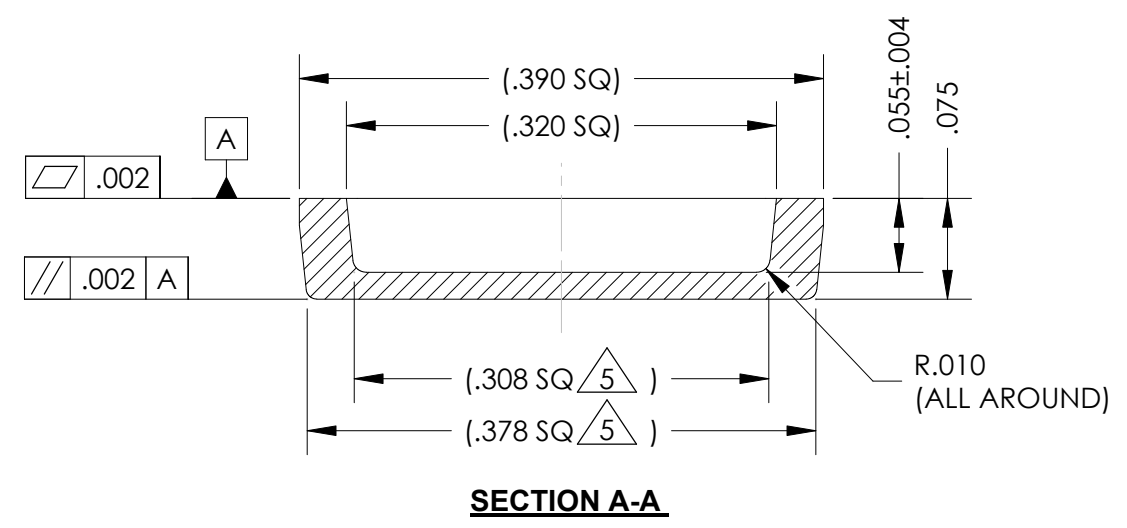

SECTION A-A

NOTES: UNLESS OTHERWISE SPECIFIED,

1. APPLICABLE STANDARDS/SPECIFICATIONS:
ASME Y14.5M-1994, DIMENSIONING AND TOLERANCING
ASME Y14.38-1999, ABBREVIATIONS AND ACRONYMS.
2. RADII: R.010 MAX.
3. PARTS TO BE CLEAN AND FREE OF FOREIGN MATERIAL.
4. LID MATERIAL: P/N 6115 (HTP-1335, NATURAL).
5. DIMENSIONED TO VIRTUAL SHARP.

CONFIDENTIAL

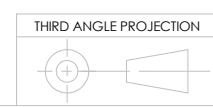

UNLESS OTHERWISE SPECIFIED:
ALL DIMS IN INCHES & INCLUDE
CHEM. APPLIED/PLATED FINISH.
REMOVE BURRS & SHARP EDGES.
DO NOT SCALE.

TOLERANCES:
.XX = ±.01
.XXX = ±.003
ANGLES = ±1°



THIS DRAWING CONTAINS INFORMATION THAT IS CONFIDENTIAL AND PROPRIETARY PROPERTY OF R.J.R. POLYMERS, INC., AND ITS DESIGN, DETAIL AND INVENTION, ARE THE PROPERTY OF R.J.R. POLYMERS, INC., SUBMITTED TO THE RECIPIENT IN CONFIDENCE AND SHALL NOT BE COPIED IN ANY MANNER NOR DISCLOSED TO ANY OUTSIDE PARTY WITHOUT THE EXPRESS WRITTEN CONSENT OF AN AUTHORIZED OFFICER OF THIS COMPANY. THEY SHALL BE USED EXCLUSIVELY FOR REFERENCE WORK ON CONTRACTS OR PROPOSALS SUBMITTED BY R.J.R. POLYMERS, INC. AND SHALL BE RETURNED ON REQUEST. THIS DRAWING MUST BE KEPT ONLY IN THE CONFIDENTIAL FILES OF R.J.R. POLYMERS, INC., WHEN NOT IN USE. ALL RIGHTS RESERVED.

MATERIAL: SEE NOTES	CAD FILE: 6542	PLASTIC LID			
FINISH: -	CLIENT: -	.390 X .390 X .075			
DATE: 03-20-09	SCALE: NTS	SIZE: B	DRAWN: D. LAM	CHK'D: -	P/N: 6542
					PAGE: 1 of 1
					REV: 01