

DRAWN	REV.	DESCRIPTION	DATE	APPROVED
D. LAM	01	INITIAL RELEASE	07-18-11	

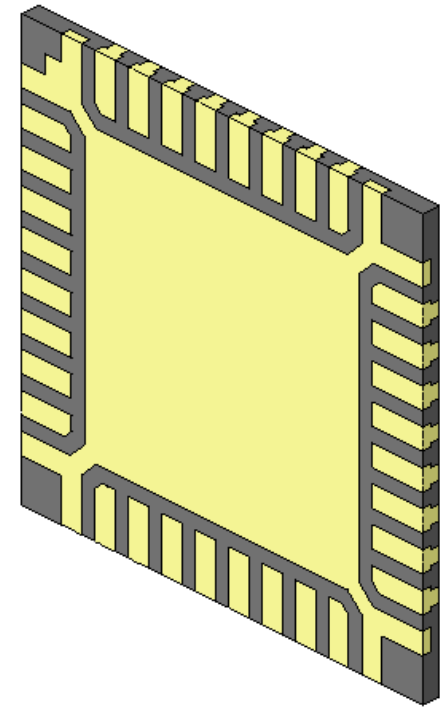

- NOTES: UNLESS OTHERWISE SPECIFIED,
- APPLICABLE STANDARDS/SPECIFICATIONS:
ASME Y14.5M-1994, DIMENSIONING AND TOLERANCING
ASME Y14.38-1999, ABBREVIATIONS AND ACRONYMS.
 - DIMENSIONS ARE SYMMETRICAL.
 - L/F MATERIAL: CDA 194 F/H, 0.2540 ±0.0076 THK (.010" THK).
 - PLATING: Ni/ Pd/ Au
 - * NICKEL PLATING: 80 μ" MIN UNDER
 - * PALLADIUM PLATING: 5-15 μ" UNDER
 - * GOLD PLATING: 3-5 μ"
 - BOTTOM CONTACT PADS ARE TO PROTRUDE OUTWARD FROM THE BODY BY 0.00 mm MIN TO 0.05 mm MAX.
 - REMOVE ALL BURRS AND SHARP EDGES MAX ALLOWABLE BURR HEIGHT TO BE 0.0254 mm (.001").

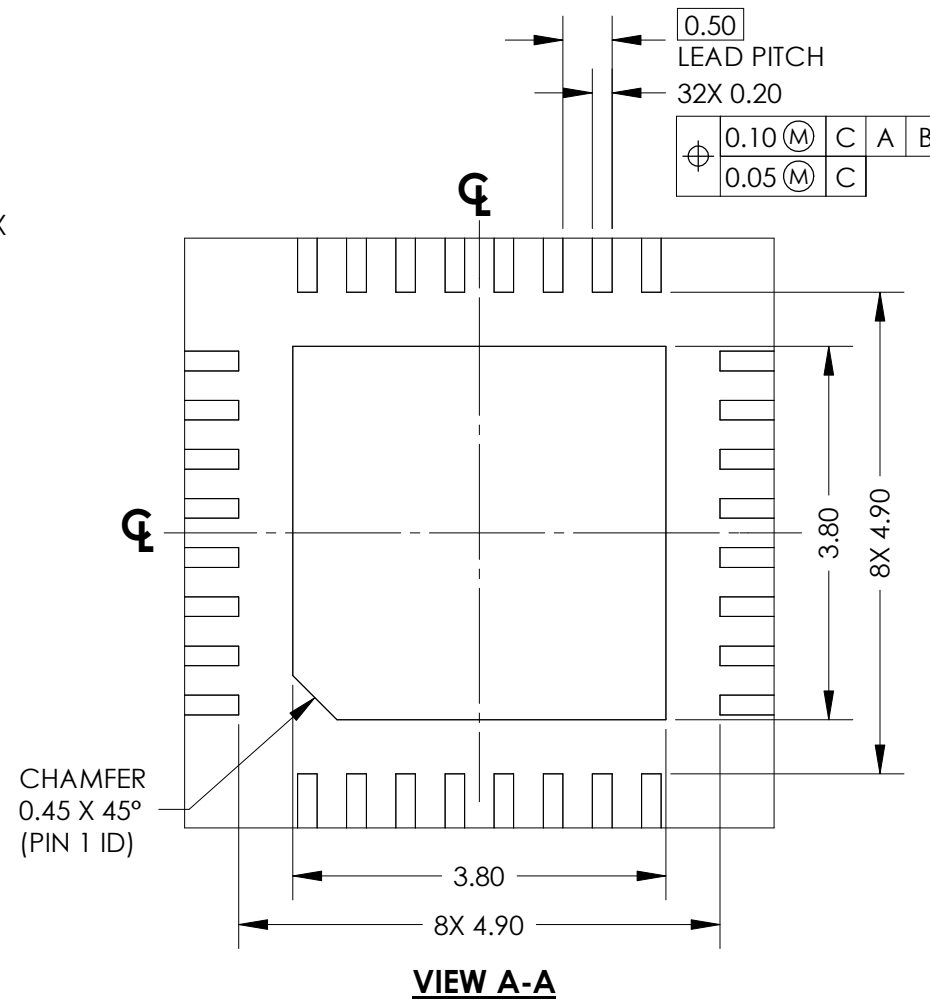
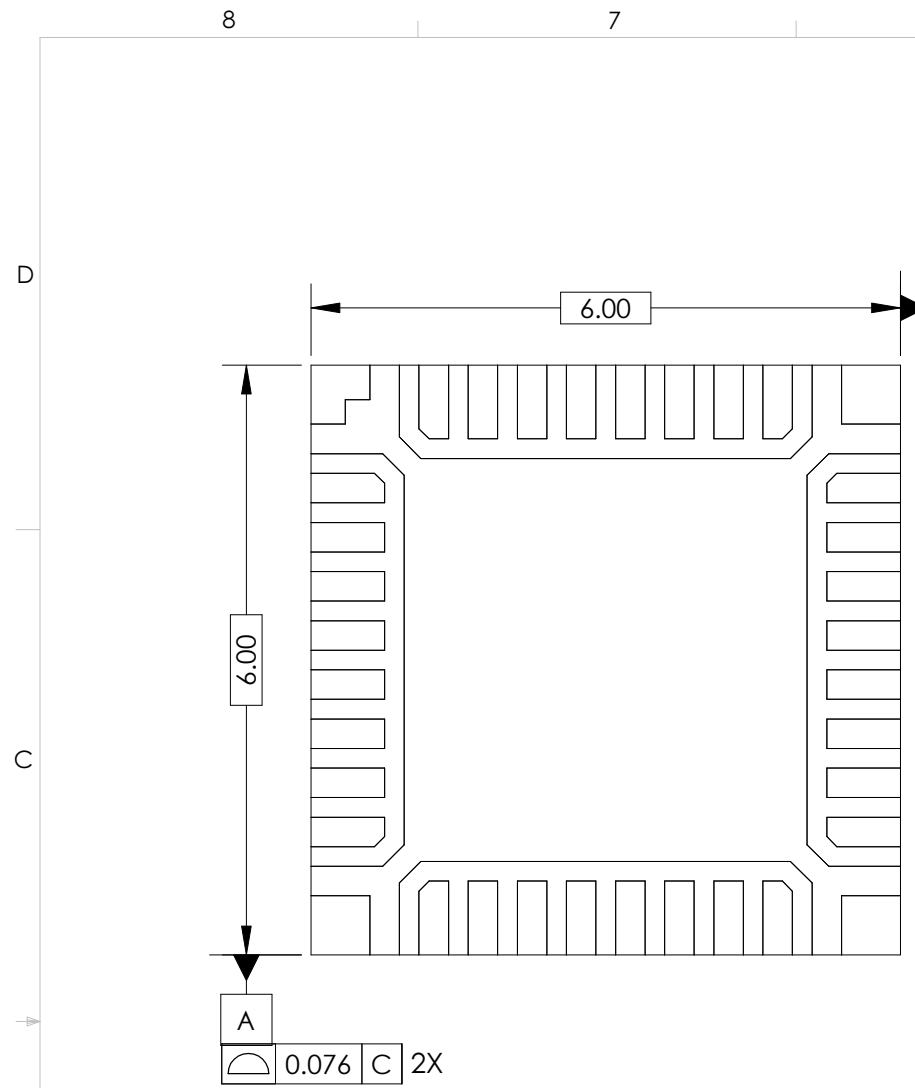
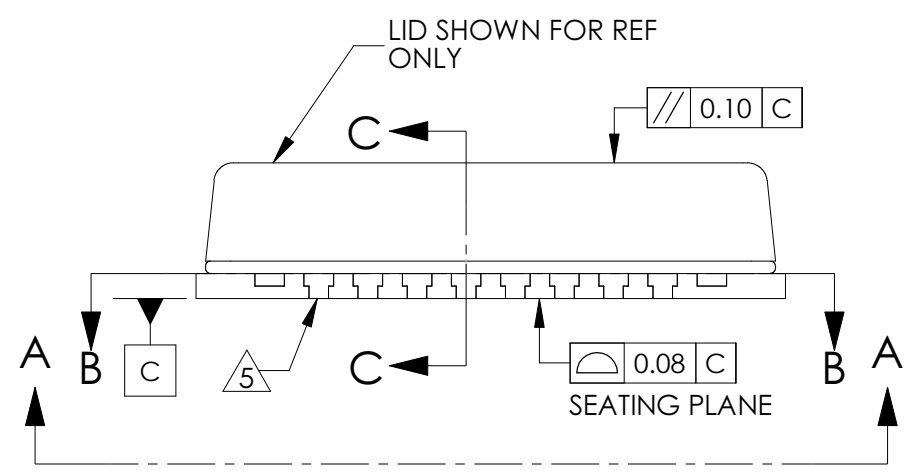

UNLESS OTHERWISE SPECIFIED:
ALL DIMS IN MILLIMETERS & INCLUDE CHEM. APPLIED/PLATED FINISH. REMOVE BURRS & SHARP EDGES. DO NOT SCALE.

TOLERANCES:
.X = ±0.076
.XX = ±0.076
.XXX = ±0.076

ANGLES = ±1°

RJR POLYMERS, INC.

THIS DRAWING CONTAINS INFORMATION THAT IS CONFIDENTIAL AND PROPRIETARY PROPERTY OF R.J.R. POLYMERS, INC., AND ITS DESIGN, DETAIL AND INVENTION, ARE THE PROPERTY OF R.J.R. POLYMERS, INC., SUBMITTED TO THE RECIPIENT IN CONFIDENCE AND SHALL NOT BE COPIED IN ANY MANNER NOR DISCLOSED TO ANY OUTSIDE PARTY WITHOUT THE EXPRESS WRITTEN CONSENT OF AN AUTHORIZED OFFICER OF THIS COMPANY. THEY SHALL BE USED EXCLUSIVELY FOR REFERENCE WORK ON CONTRACTS OR PROPOSALS SUBMITTED BY R.J.R. POLYMERS, INC. AND SHALL BE RETURNED ON REQUEST. THIS DRAWING MUST BE KEPT ONLY IN THE CONFIDENTIAL FILES OF R.J.R. POLYMERS, INC., WHEN NOT IN USE. ALL RIGHTS RESERVED.

CAD FILE: RQFNA-04-00

CLIENT: -

DATE: 06-20-11

SCALE: NTS

SIZE: B

DRAWN: D. LAM

CHK'D: -

P/N: RQFNA-04-00

PAGE: 1 of 2

REV: 01

CONFIDENTIAL

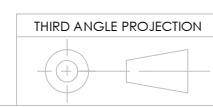

8 7 6 5 4 3 2 1

D
C
B
A

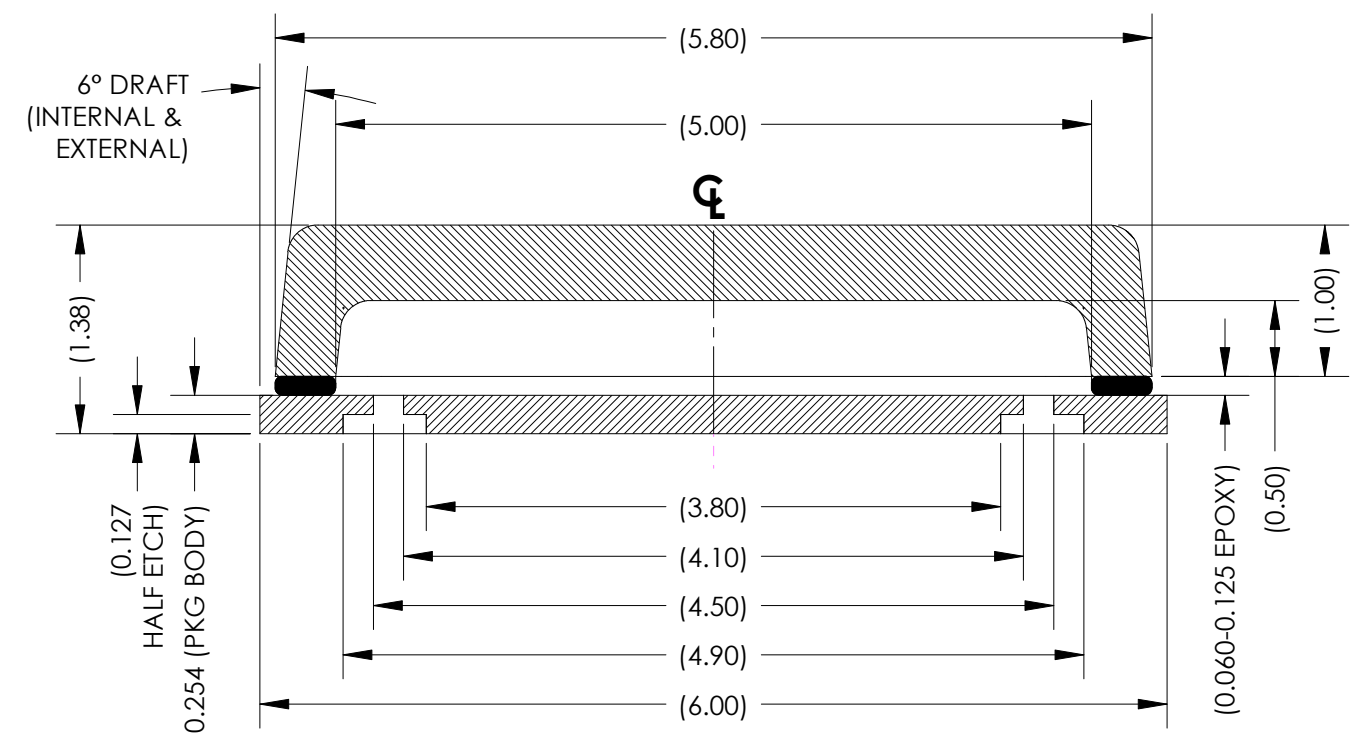
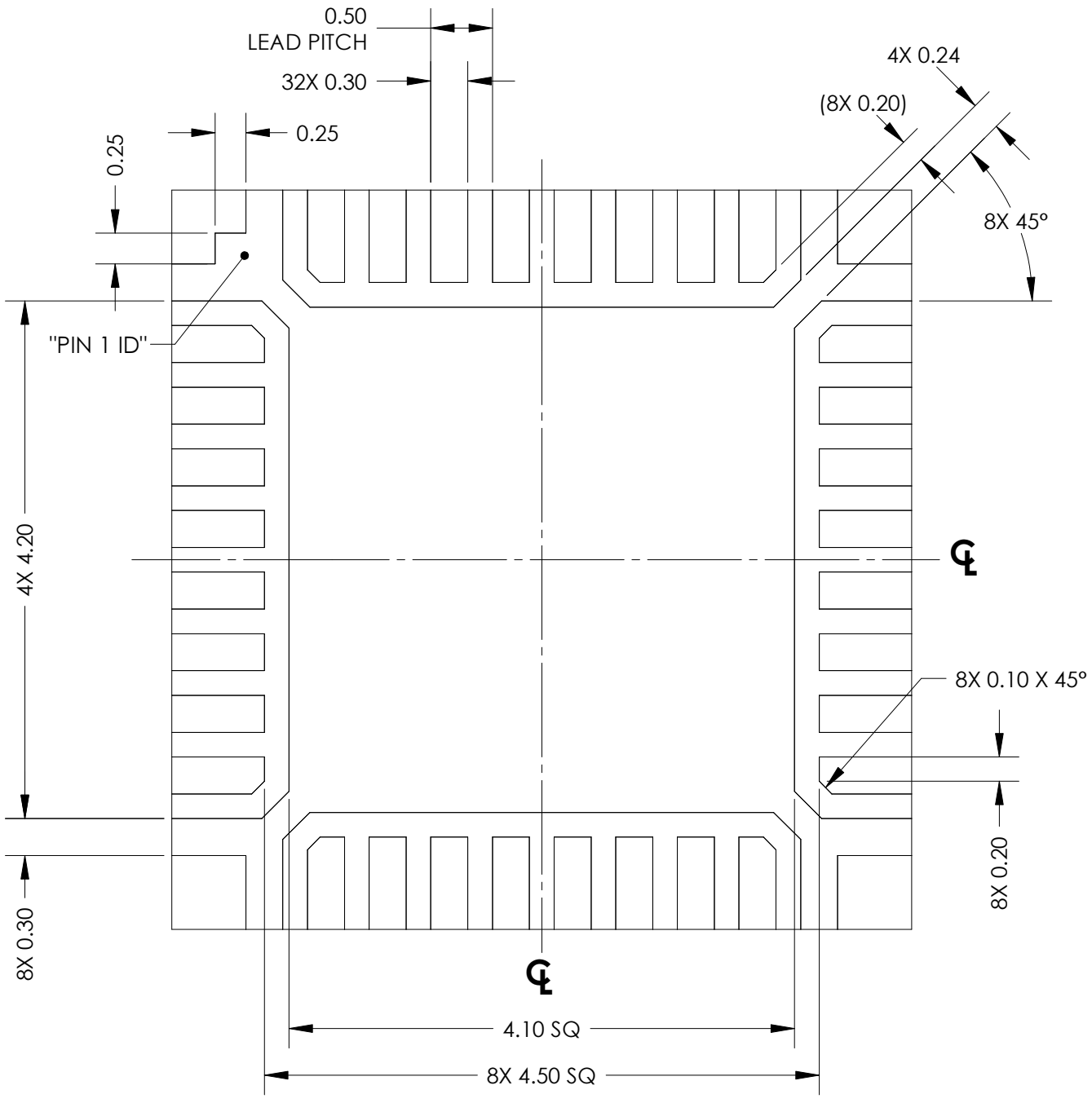

D
C
B
A

CONFIDENTIAL

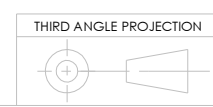

UNLESS OTHERWISE SPECIFIED:
ALL DIMS IN MILLIMETERS & INCLUDE CHEM. APPLIED/PLATED FINISH. REMOVE BURRS & SHARP EDGES. DO NOT SCALE.

TOLERANCES:
.X = ±0.076 ANGLES = ±1°
.XX = ±0.025
.XXX = ±0.013

MATERIAL:
SEE NOTES

FINISH:
-

THIS DRAWING CONTAINS INFORMATION THAT IS CONFIDENTIAL AND PROPRIETARY PROPERTY OF R.J.R. POLYMERS, INC., AND ITS DESIGN, DETAIL AND INVENTION, ARE THE PROPERTY OF R.J.R. POLYMERS, INC., SUBMITTED TO THE RECIPIENT IN CONFIDENCE AND SHALL NOT BE COPIED IN ANY MANNER NOR DISCLOSED TO ANY OUTSIDE PARTY WITHOUT THE EXPRESS WRITTEN CONSENT OF AN AUTHORIZED OFFICER OF THIS COMPANY. THEY SHALL BE USED EXCLUSIVELY FOR REFERENCE WORK ON CONTRACTS OR PROPOSALS SUBMITTED BY R.J.R. POLYMERS, INC. AND SHALL BE RETURNED ON REQUEST. THIS DRAWING MUST BE KEPT ONLY IN THE CONFIDENTIAL FILES OF R.J.R. POLYMERS, INC., WHEN NOT IN USE. ALL RIGHTS RESERVED.

RJR POLYMERS, INC.

CAD FILE: RQFNA-04-00

CLIENT: -

DATE: 06-20-11

SCALE: NTS

SIZE: B

DRAWN: D. LAM

CHK'D: -

P/N: RQFNA-04-00

PAGE: 2 of 2

REV: 01

**32 LDS QFN, PACKAGE OUTLINE
6mm X 6mm**

8 7 6 5 4 3 2 1